

2 - Hood

CODE	DESCRIPTION
160704	BLACK PLUG WITH GASKET 1/2"GAK
160793	PLUG
180108	PLASTIC NUT 1/2"
210404	BLACK RUBBER FOOT S90 NE SE
322711	RIGHT RAIL GE
322712	RAIL LEFT GE
332352	BRACKET
342246	HOOD+TANK GE100
351397	RIGHT SIDE PANEL GE
351398	SIDE LEFT PANEL GE
351405	TOP PANEL GE115
351414	SIDE LEFT PANEL GE
351415	SIDE RIGHT PANEL GE
351736	FRONT PANEL GE115
351740	CONTROL PANEL GE
351783	FRONT PANEL GE100
351944	BACK PANEL GE115
351945	UPPER BACK PANEL GE115
361067	FRAME GE100
450821	SPRING CLIP FASTENER SNU 3634
460435	ISOLATION PANEL
620222	COMPLETE ALUMINIUM LEGS

3 - Door component

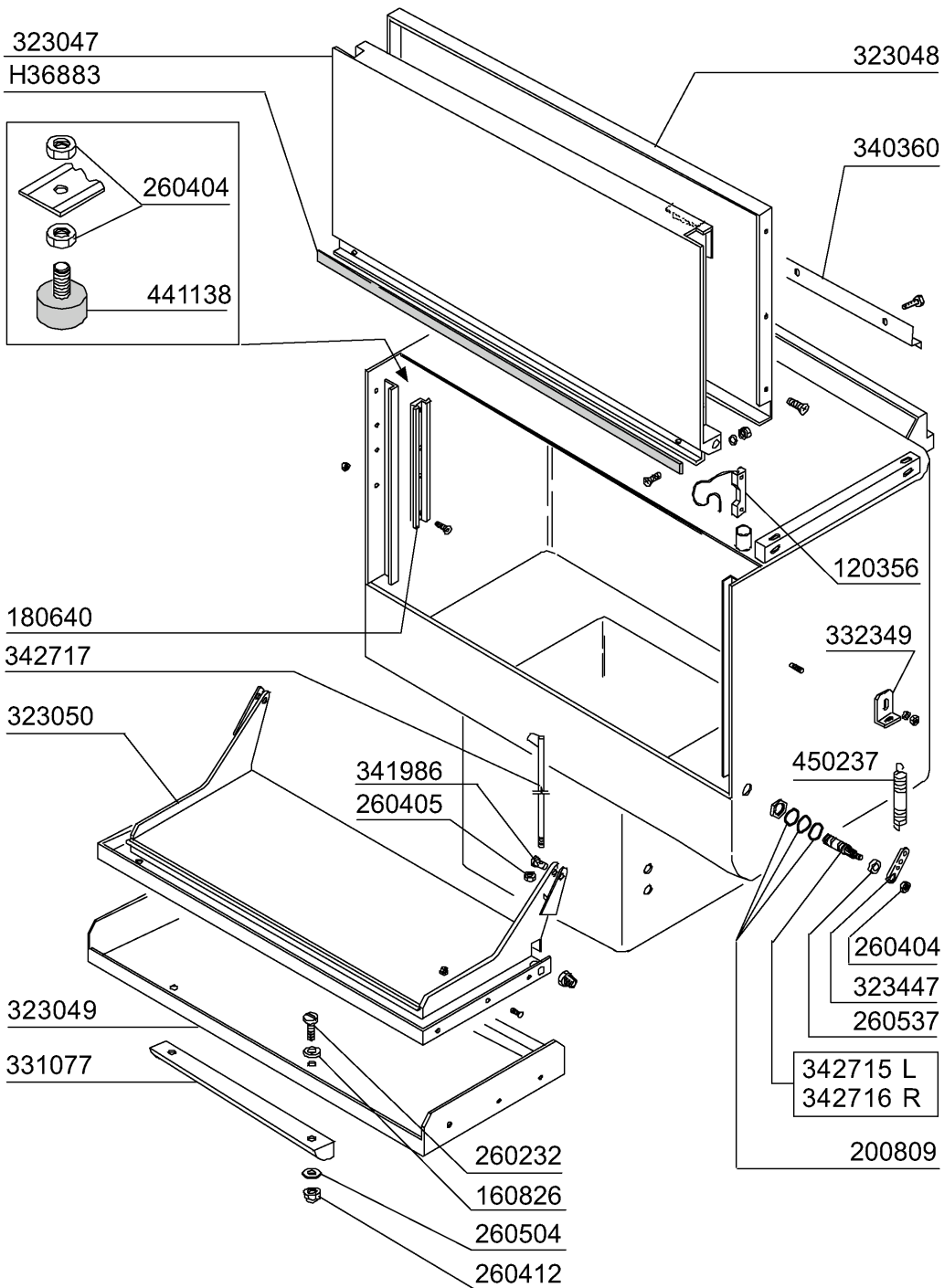

09 - 2008 M.S.A.

3 - Door component

CODE	DESCRIPTION
120356	DOOR MAGN.SWITCH
160826	GASKET 14X6,2X2 B41-F2
180640	DOOR RAIL FOR GE
200809	OR GASKET 1,78X8,73X12,29
260232	STAINL.ST TB SCREW 6X25 B15-6-
260404	STAINLESS STEEL NUTS D6 UNI 55
260405	NUT D.8
260412	SELF-LOCKING NUT M6
260504	ST/ST FLAT WASHER D6
260537	STAINL.STEEL FLAT WASHER D13X2
323047	UPPER DOOR GE100-115
323048	BACK PANEL FOR UPPER DOOR GE10
323049	LOWER DOOR GE100-115
323050	BACK PANEL FOR LOWER DOOR GE10
323447	SPRING CONNECTION
331077	GE DOOR HANDLE
332349	BRACKET FOR DOOR SPRING GE
340360	BRACKET GE115
341986	"GL"-DOOR PIN
342715	LEFT SPINDLE FOR GE DOOR
342716	RIGHT SPINDLE GE DOOR
342717	DOOR SPINDLE
441138	PROTECTION
450237	DOOR SPRING GE
H36883	GASKET FOR DOOR GE

4 - Upper wash and rinse arms

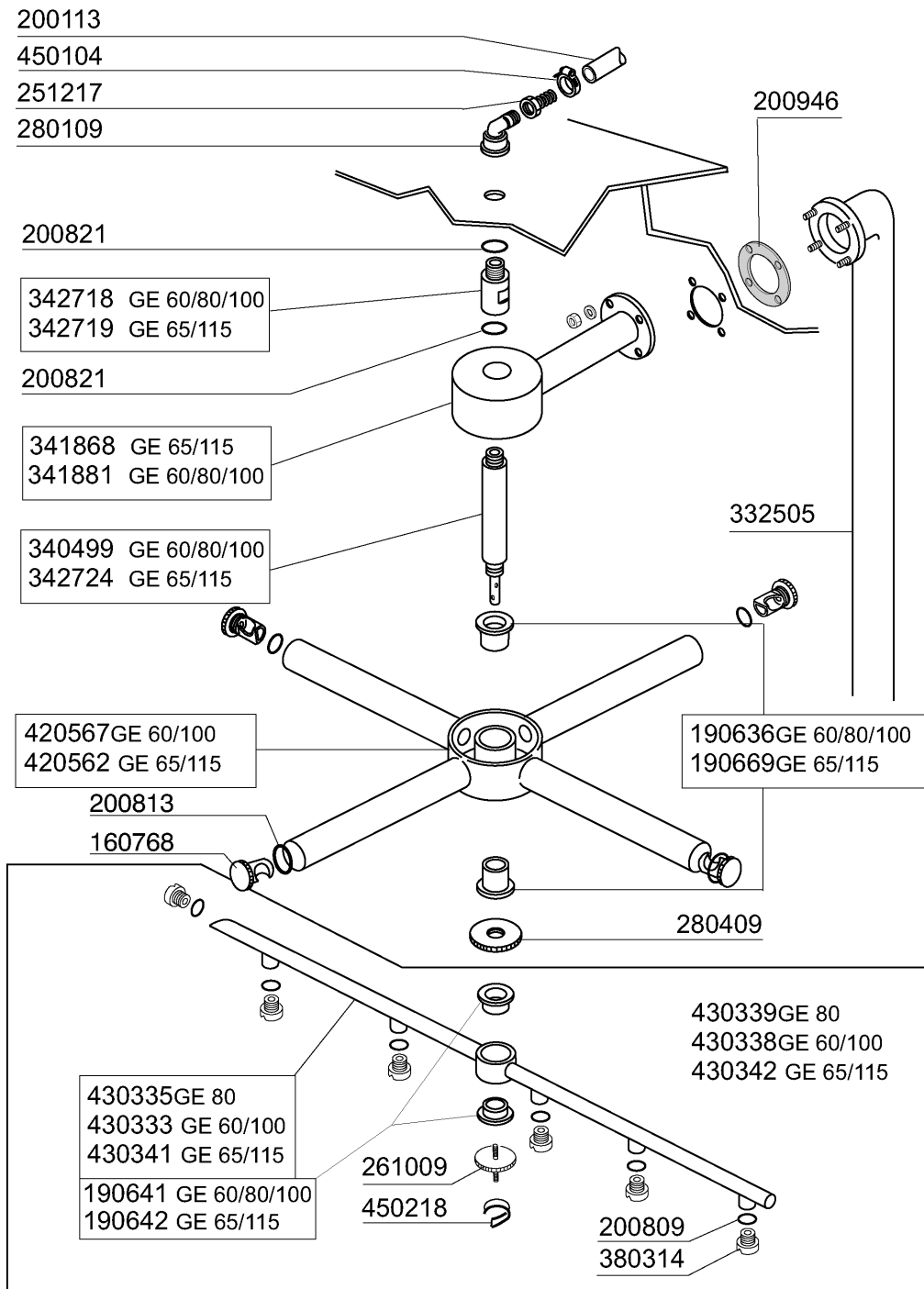

08 - 2008 M.SA

4 - Upper wash and rinse arms

CODE	DESCRIPTION
160768	PLUG FOR "C95-155" WASH ARM
190636	BUSH FOR C95-155-165 WASH ARM
190641	BUSH FOR C95-155-165 RINSE ARM
190642	BUSH FOR S/S RINSE ARM "G"
190669	BUSH WASH ARM GE
200113	RUBBER HOSE 12 X 22
200809	OR GASKET 1,78X8,73X12,29
200813	OR GASKET 2,21X16,36X20,78
200821	O-RING 2,62X20,63
200946	GASKET WASH COLUMN GE
251217	ST/ST NIPPLE 3/8
261009	RETAIN.SCREW FOR WASH-RINSE AR
280109	CRANK 90Ø F.F 3/8"
280409	RETAIN.LOCK NUT CENTR.CROSS C1
332505	GE WASH COLUMN
340499	SPINDLE CENTR. CROSS C34
341868	GE65 WASH ARM SUPPORT
341881	GE60 WASH ARM SUPPORT
342718	RINSE SPINDLE GE60
342719	RINSE SPINDLE GE65
342724	WASH ARM SPINDLE GE65
380314	RINSE JETS 801/HR
420562	WASH ARM GE65-115
420567	WASH ARM GE60-100
430333	RINSE ARM WITHOUT NOZZLE GE100
430335	RINSE ARM WITHOUT NOZZLES GE80
430338	RINSE ARM GE100
430339	RINSE ARM GE80
430341	RINSE ARM WITHOUT NOZZLES GE65
430342	RINSE ARM GE65
450104	CLAMP FE ZN H=12,5 15-24
450218	SPRING F.RINSE ARM RETAIN.SCRE

5 - Lower wash and rinse arms

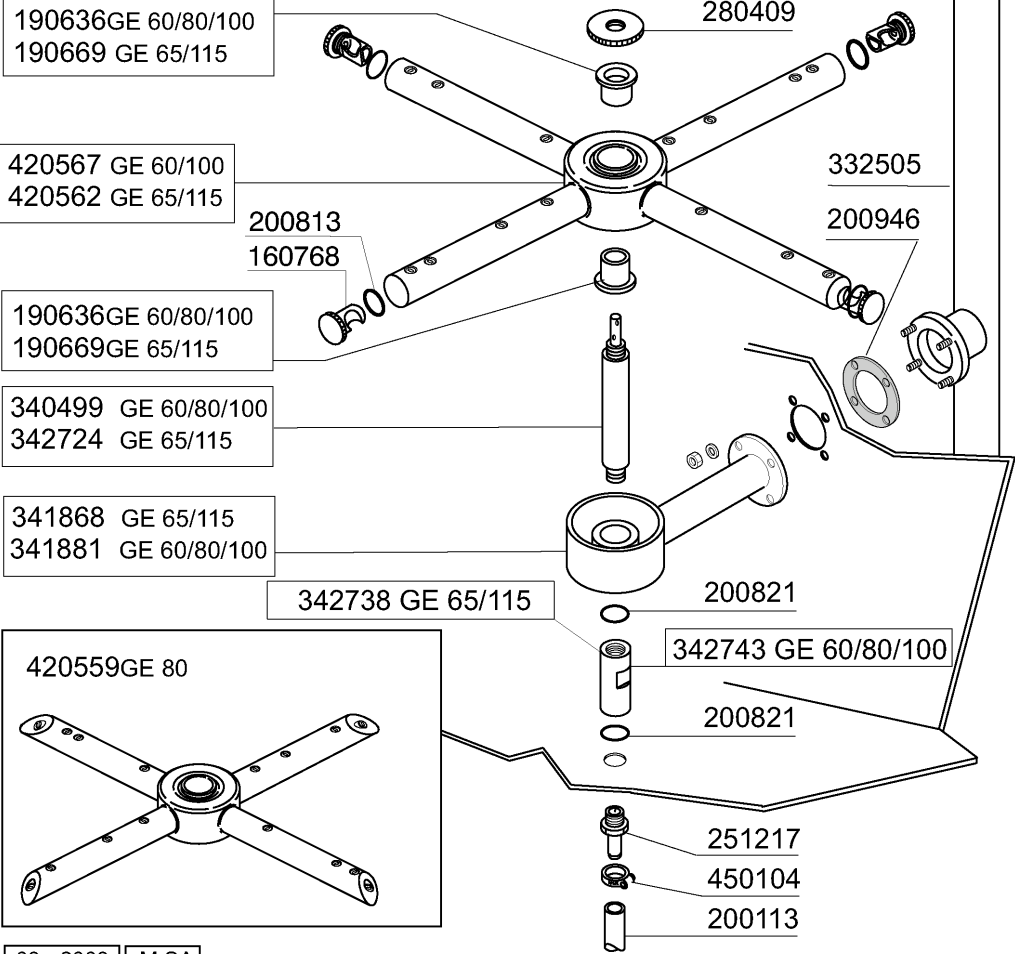
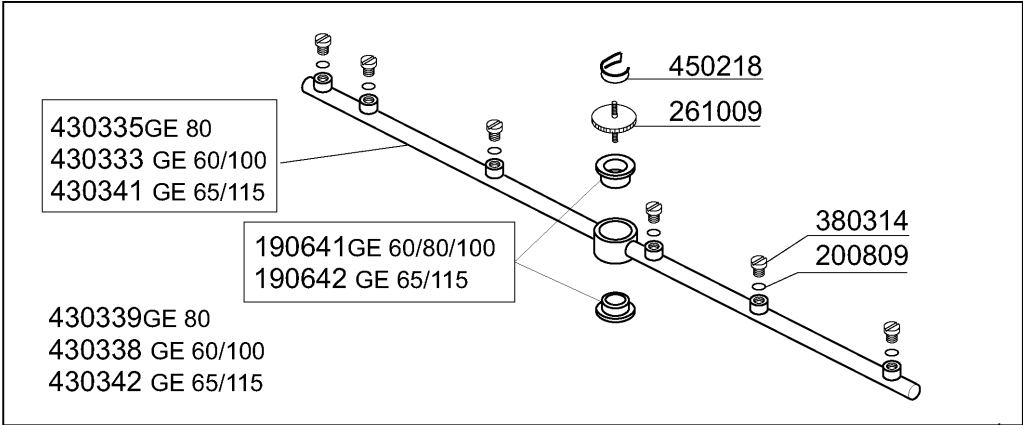

08 - 2008 M.SA

5 - Lower wash and rinse arms

CODE	DESCRIPTION
160768	PLUG FOR "C95-155" WASH ARM
190636	BUSH FOR C95-155-165 WASH ARM
190641	BUSH FOR C95-155-165 RINSE ARM
190642	BUSH FOR S/S RINSE ARM "G"
190669	BUSH WASH ARM GE
200113	RUBBER HOSE 12 X 22
200809	OR GASKET 1,78X8,73X12,29
200813	OR GASKET 2,21X16,36X20,78
200821	O-RING 2,62X20,63
200946	GASKET WASH COLUMN GE
251217	ST/ST NIPPLE 3/8
261009	RETAIN.SCREW FOR WASH-RINSE AR
280409	RETAIN.LOCK NUT CENTR.CROSS C1
332505	GE WASH COLUMN
340499	SPINDLE CENTR. CROSS C34
341868	GE65 WASH ARM SUPPORT
341881	GE60 WASH ARM SUPPORT
342724	WASH ARM SPINDLE GE65
342738	EXTENSION
342743	EXTENSION
380314	RINSE JETS 801/HR
420559	WASH ARM GE80
420562	WASH ARM GE65-115
420567	WASH ARM GE60-100
430333	RINSE ARM WITHOUT NOZZLE GE100
430335	RINSE ARM WITHOUT NOZZLES GE80
430338	RINSE ARM GE100
430339	RINSE ARM GE80
430341	RINSE ARM WITHOUT NOZZLES GE65
430342	RINSE ARM GE65
450104	CLAMP FE ZN H=12,5 15-24
450218	SPRING F.RINSE ARM RETAIN.SCRE

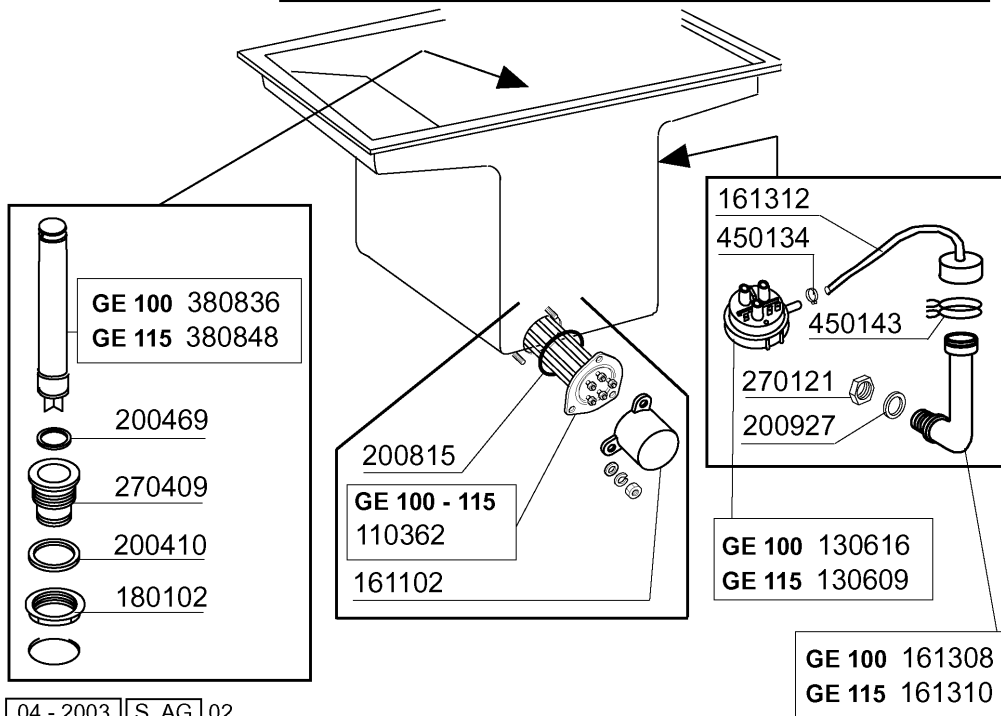
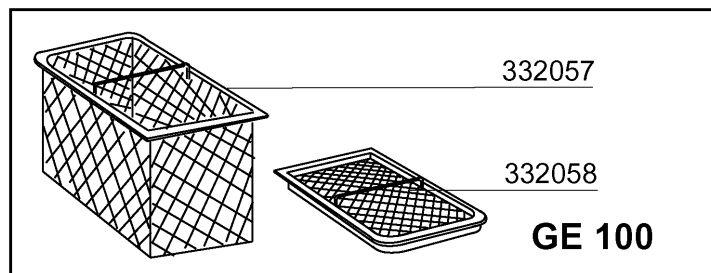
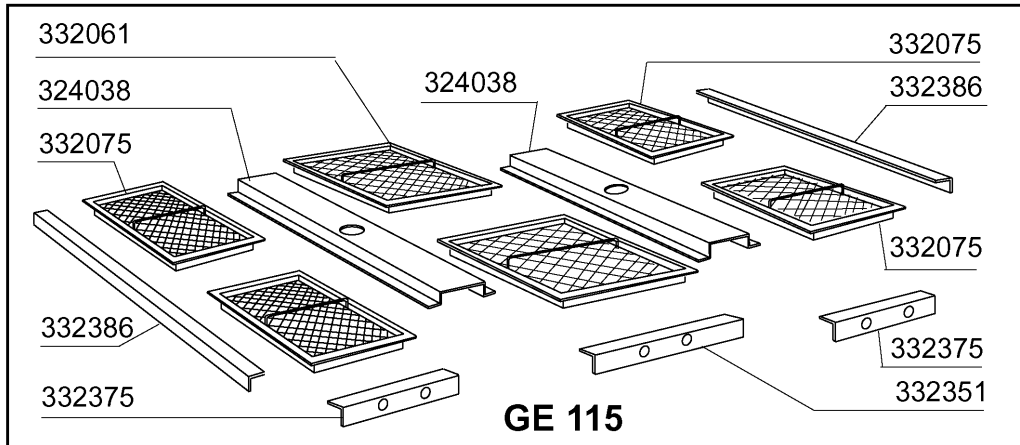

04 - 2003 | S.A.G. | 02

6 - Filters

CODE	DESCRIPTION
110362	HEAT.ELEMENT 9000W 220/380V
130609	1 LEVEL PRESSURE SWITCH 110-70
130616	PRESSURE SWITCH 190/80 FOR C95
161102	ELEMENT COVER MOPL.
161308	AIR CHAMBER C95-155
161310	AIR CHAMBER FOR GLASSWASHERS B
161312	HOSE FOR PRESSURE SWITCH C95-1
180102	DRAIN PIPE NUT 1"1/2 F45-55
200410	DRAIN OUTL.WASH.1 1/2"65X47X2
200469	STAND PIPE O RING 45X35,5X7
200815	O-RING F. HEAT.ELEM.
200927	GASKET FOR AIR TRAP
270121	NUT FOR AIR TRAP
270409	DRAIN OUTLET AC-ACR
324038	CROSS PART F.FILTER SUPP.
332057	GE100 TANK FILTER
332058	DRAW FILTER GE100
332061	CENTRAL FILTER GE115
332075	TANK FILTER GE65-115
332351	CENTRAL FILTER SUPPORT GE115
332375	FILTER SUPPORT GE65-115
332386	LEFT FILTER SUPPORT GE65
380836	OVERFLOW PIPE MM.415
380848	OVERFLOW PIPE GE65-115
450134	ELASTIC HOSE CLIP D.9,3/8,8
450143	CLAMP D.39,7 X 37,7

Fino a...
 Bis zum... **08/2006**
 Up to...
 Jusqu'à...
 Hasta...



100361(2Hp)

A partire da...
 From... **09/2006**
 Ab.....
 Despues...
 A partir de...



100786(3Hp)

GE 60 - 80 - 100

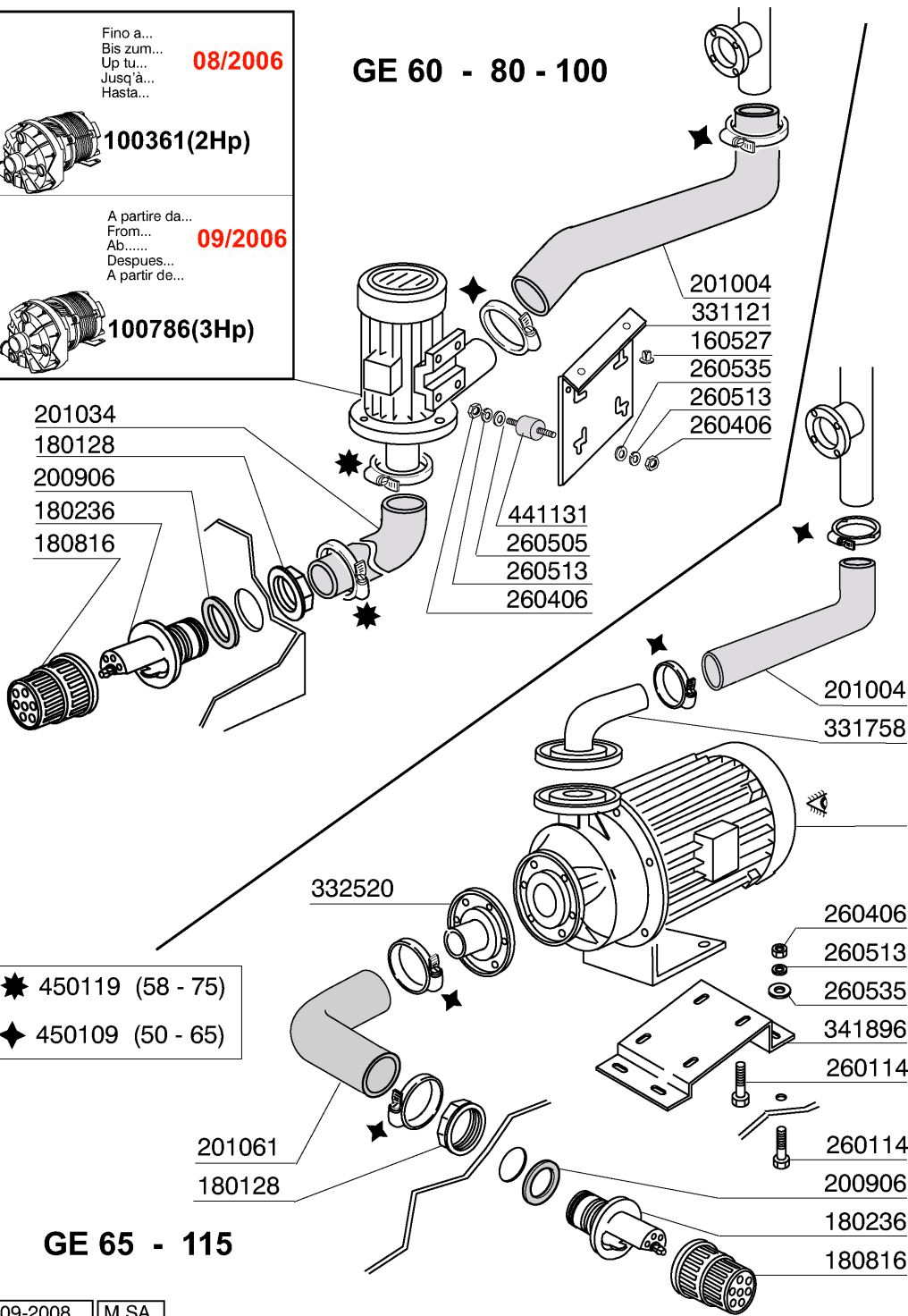

- ★ 450119 (58 - 75)
- ◆ 450109 (50 - 65)

GE 65 - 115

09-2008 | M.S.A.

7 - Wash pump

CODE	DESCRIPTION
100361	PUMP HP 2-220/380-50HZ-120404
100786	PUMP HP 3 V.230-400-50HZ
160527	PLUG 14,5X2X8
180128	RING NUT 65,4 C140 C85
180236	PUMP SUCTION FOR AC-ACR-C155
180816	STRAINER OF INLET PUMP AC-ACR
200906	GASKET D.92X66X2
201004	OUTLET HOSE AC95-AC135
201034	WASH TANK INLET HOSE
201061	INLET HOSE 4HP PUMP GE
260114	SCREW TE 8X25
260406	NUT 8MA
260505	STAINL.STEEL FLAT WASHER D8
260513	GROWER WASHER D8
260535	STAINL.ST WASHER 24X8,5X2
331121	FIXING PLATE FOR PUMP ACR
331758	BRACKET F.SOLEN.VALV SE
332520	FLANGE WASH PUMP GE
341896	PUMP SUPPORT
441131	VIRATION- DAMPING 40X30X8
450109	CLAMP 50-65
450119	CLAMP FE ZN. 58-75 H=12,2

8 - Rinse assembly

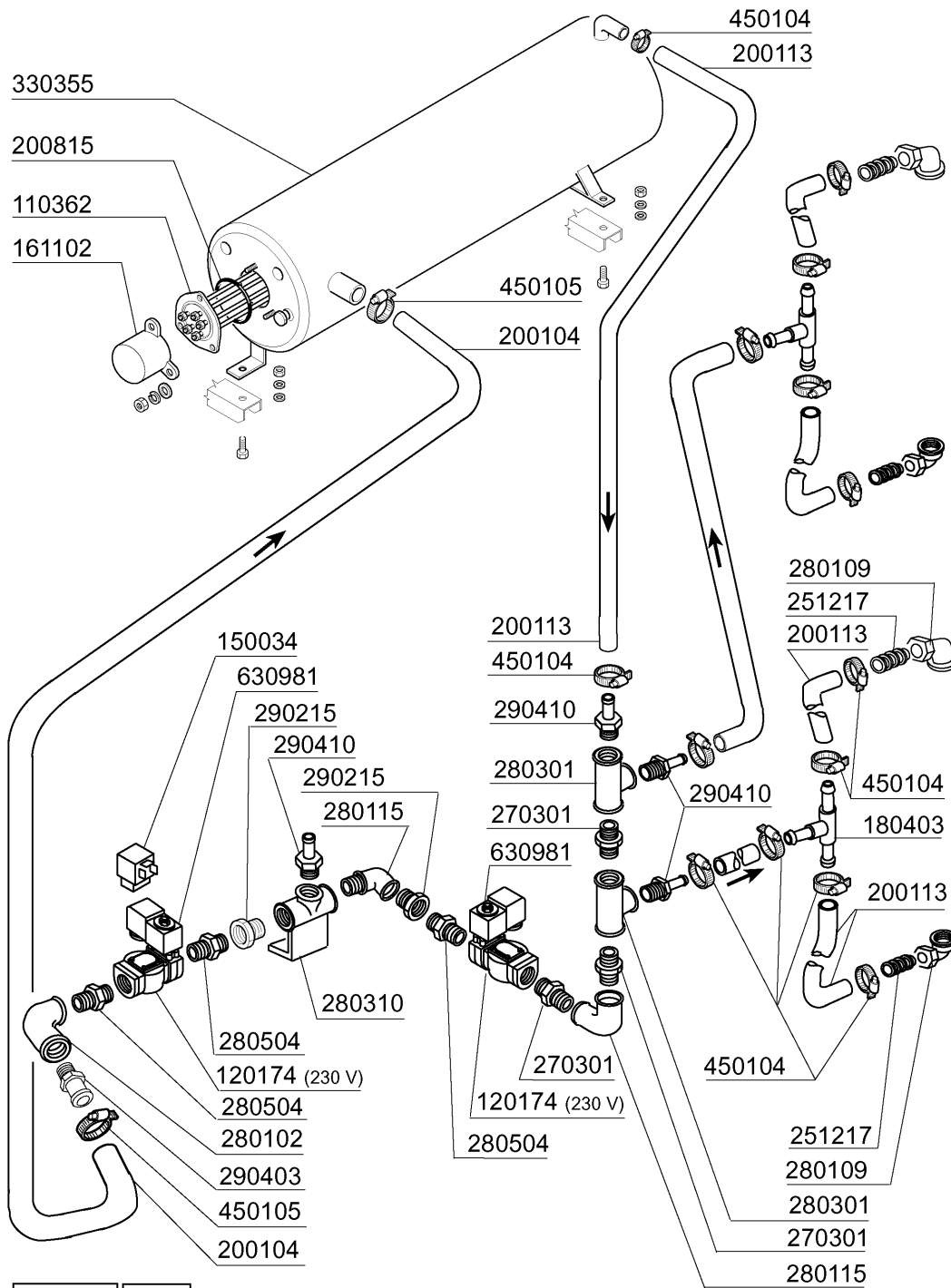

04 - 2003 | A. Z.

8 - Rinse assembly

CODE	DESCRIPTION
110362	HEAT.ELEMENT 9000W 220/380V
120174	SOLEN. VALVE L180V31 1/2"-V220
150034	CONNEC.F.SOLEN.VALVE 122.09.N
161102	ELEMENT COVER MOPL.
180403	TEE-NIPPLE F2-F300-B10-11
200104	DISCHARGE HOSE 20X30
200113	RUBBER HOSE 12 X 22
200815	O-RING F. HEAT.ELEM.
251217	ST/ST NIPPLE 3/8
270301	BRASS NIPPLES 1/2"
280102	ELL FF 3/4"
280109	CRANK 90° F.F 3/8"
280115	ELL 1/2"
280301	TEE 1/2"
280310	TEE-CONNECTION 1/2"
280504	MANIFOLD CONN.HOSE
290215	1/2"BSP M/F UNION BRASS
290403	NIPPLE M.3/4" BRASS
290410	NIPPLE 1/2"
330355	BOOSTER GE
450104	CLAMP FE ZN H=12,5 15-24
450105	CLAMP FE ZN. 26-38 H=12,2
630981	COIL Z610 220/240V 50/60HZ

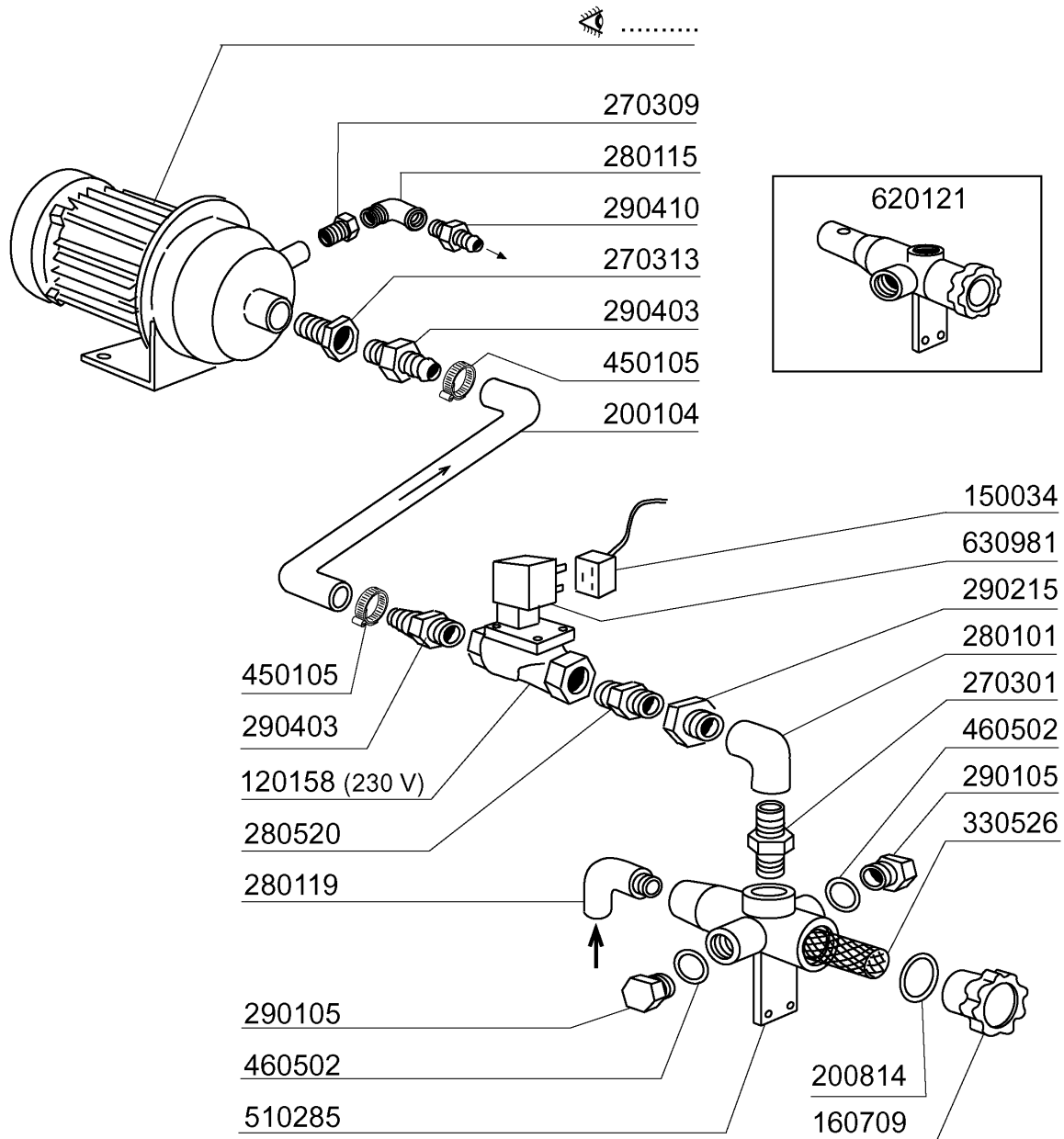

9 - Rinse pump

CODE	DESCRIPTION
120158	SOLEN. VALVE 3/4 L180Q17 240V
150034	CONNEC.F.SOLEN.VALVE 122.09.N
160709	KNOB OF MANIFOLD F. SOLEN. VAL
200104	DISCHARGE HOSE 20X30
200814	O-RING 34,52X41,58X3,53
270301	BRASS NIPPLES 1/2"
270309	CONNECTION 1"-1/2"
270313	CONNECT.1 1/4" - 3/4"
280101	CRANK F.F 1/2"
280115	ELL 1/2"
280119	ELL MF 3/4"
280520	CONNECTION 3/4"
290105	BRASS-TE-PLUG 1/2"
290215	1/2"BSP M/F UNION BRASS
290403	NIPPLE M.3/4" BRASS
290410	NIPPLE 1/2"
330526	FILTERS 22X28 SOLENOID V.MANIF
450105	CLAMP FE ZN. 26-38 H=12,2
460502	GASKET 30X21X2
510285	SOLENOID VALVE MANIFOLD - BRAS
620121	TWIN SOLENOID VALVE MANIFOLD
630981	COIL Z610 220/240V 50/60HZ

10 - Control box

CODE	DESCRIPTION
110482	CABLE FOR PCB FC-C-GE
120459	AUXIL.RELE 16A 220V
120460	RELAY 16A 220V
120477	CONTACTOR ABB 9A 220V 50/60HZ
120488	CONTACTOR ABB 12A 220V 50/60HZ
120489	CONTACTOR ABB 16A 220V 50/60HZ
120519	SECURITY THERMOSTAT 95-125Ø
120860	OVERLOAD RELAY ABB 1-1,4A
120863	OVERLOAD RELAY ABB 2,8-4A
120864	OVERLOAD RELAY ABB 4,5-6,5A
120865	OVERLOAD RELAY ABB 6-8,5A
120867	OVERLOAD RELAY ABB 10-14A
120960	PROBE C-G
121283	ELECTRONIC PANEL "C-GE"
121284	ELECTRONIC CONTROL PANEL C-GE
130237	FUSE 14X51 32A GL14332
130252	FUSE 20A GF 12320
130260	FUSE 10,3X38 2A AM 13001
150710	FUSE CARRIER 10,3X38 ART.21401
160537	ELECTRONIC CARD SPACER
161175	PROTECTION
200432	SPONGY RUBBER ADHESIV 8X4 NEOP
260423	SELF-LOCKING NUT M3
260501	STAINL.STEEL FLAT WASHER D3 UN
290801	FIXING SCREW
351740	CONTROL PANEL GE
461353	PLATE C-GE ELECTRONIC
631209	ANTI-NOISE FILTER
870016	LITTLE SWITCH FOR PCB
870017	BIGGER SWITCH FOR PCB
H36019	COVER FOR GE PCB

630529

631661 50 Hz Ø 122
631696 60 Hz

200848

630128

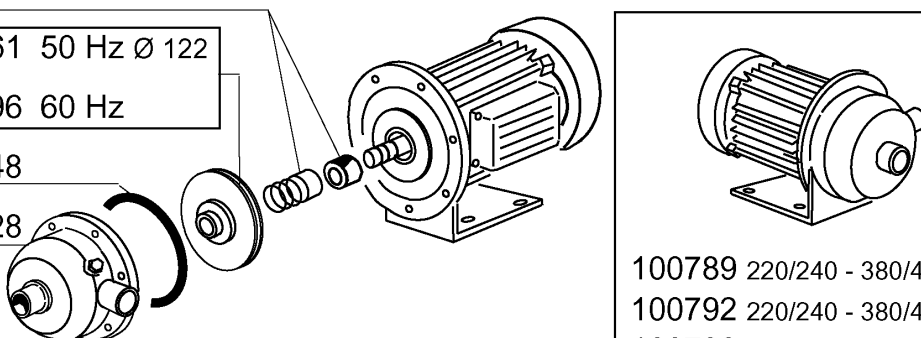

HP 0,75 / Kw 0,55 (CEA 120/2/A)

100789 220/240 - 380/415 50 Hz
100792 220/240 - 380/415 60 Hz
100793 255/440 60 Hz

630216

630306

630223

630501

631618 50 Hz
631647 60 Hz

630411

630114

POMPA LAVAGGIO - WASH PUMP
POMPE LAVAGE - WASCHPUMPE
BOMBA LAVADO HP 2 / Kw 1,5 (1204)

GE 60 - 80 - 100

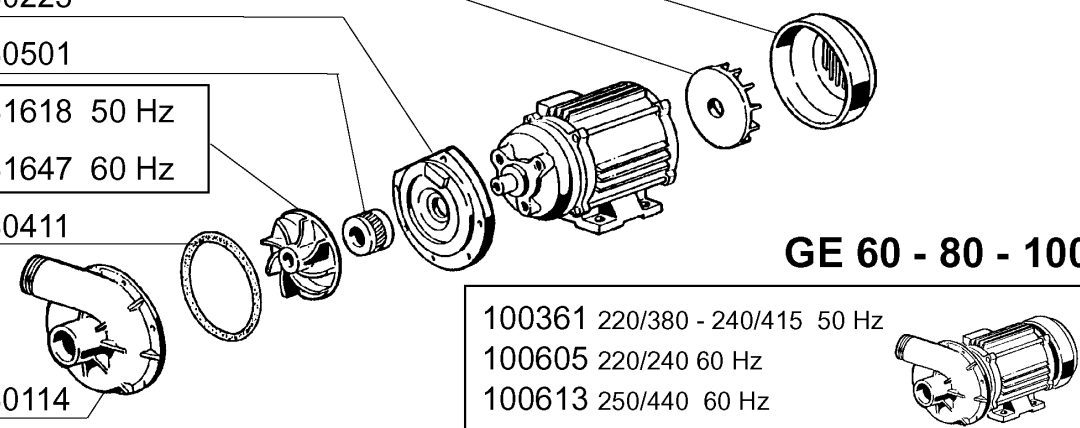

100361 220/380 - 240/415 50 Hz
100605 220/240 60 Hz
100613 250/440 60 Hz

GE 65 - 115

630520

631693 50 Hz Ø 116
631694 60 Hz Ø 90

200948

460526

460525

POMPA LAVAGGIO - WASH PUMP
POMPE LAVAGE - WASCHPUMPE
BOMBA LAVADO - HP 4 / Kw 3 (SHE 50)

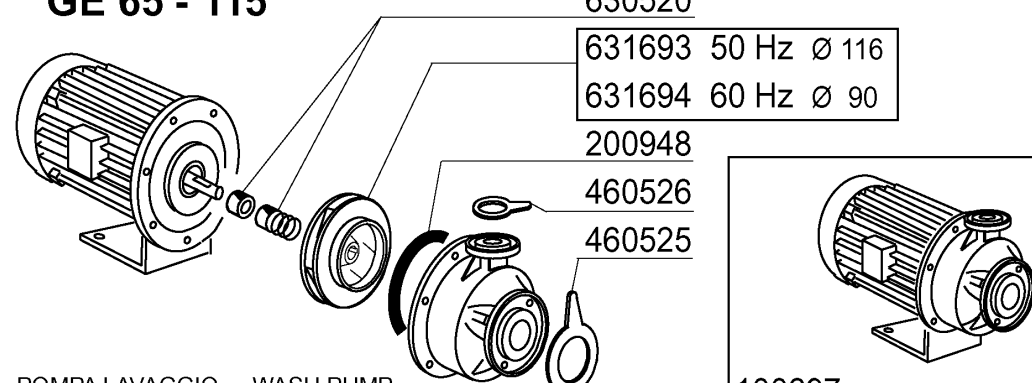

100697 220/240 - 380/415 50 Hz
100709 220/240 - 380/415 60 Hz

11 - Pump

CODE	DESCRIPTION
100361	PUMP HP 2-220/380-50HZ-120404
100605	PUMP HP 2 380/3/60HZ 1204
100613	PUMP HP 2 440/3/60HZ 1204
100697	PUMP HP 4 230/400/50 SHE 50
100709	PUMP HP 4 220/380/415V 60HZ
100789	PUMP HP 0,75 220/415V
100792	PUMP HP 0,75 220/415
100793	PUMP HP 0,75
200848	O-RING FOR PUMP 0,75 HP CEA 12
200948	OR GASKET
460525	GASKET INLET ELBOW WASH PUMP
460526	GASKET DELIVERY ELBOW WASH P.
630114	VOLUTE FI HP2-2,7-3-3,2
630128	PUMP VOLUTE 0,75HP CEA120/2
630216	FAN HOUSING FIR HP 2-3
630223	BACK PLATE PUMP HP2-3-3,2
630306	PUMP FAN IMPELLOR FI HP.2-3
630411	O-RING PUMP FI HP 2-2,7
630501	SEAL FOR PUMP HP 2-3-3,2
630520	PUMP SEAL HP4-HTE50E
630529	SEAL FOR PUMP HP0,75 CEA120/2A
631618	IMPELLER PUMP F HP2-D.116,5
631647	IMPELLER D.100-60HZ-1204/5
631661	IMPELLER PUMP 0,75HP LOW.CE120
631693	IMPELLER FOR PUMP 100697
631694	IMPELLER
631696	IMPELLER 60HZ FOR PUMP 100792

WP3

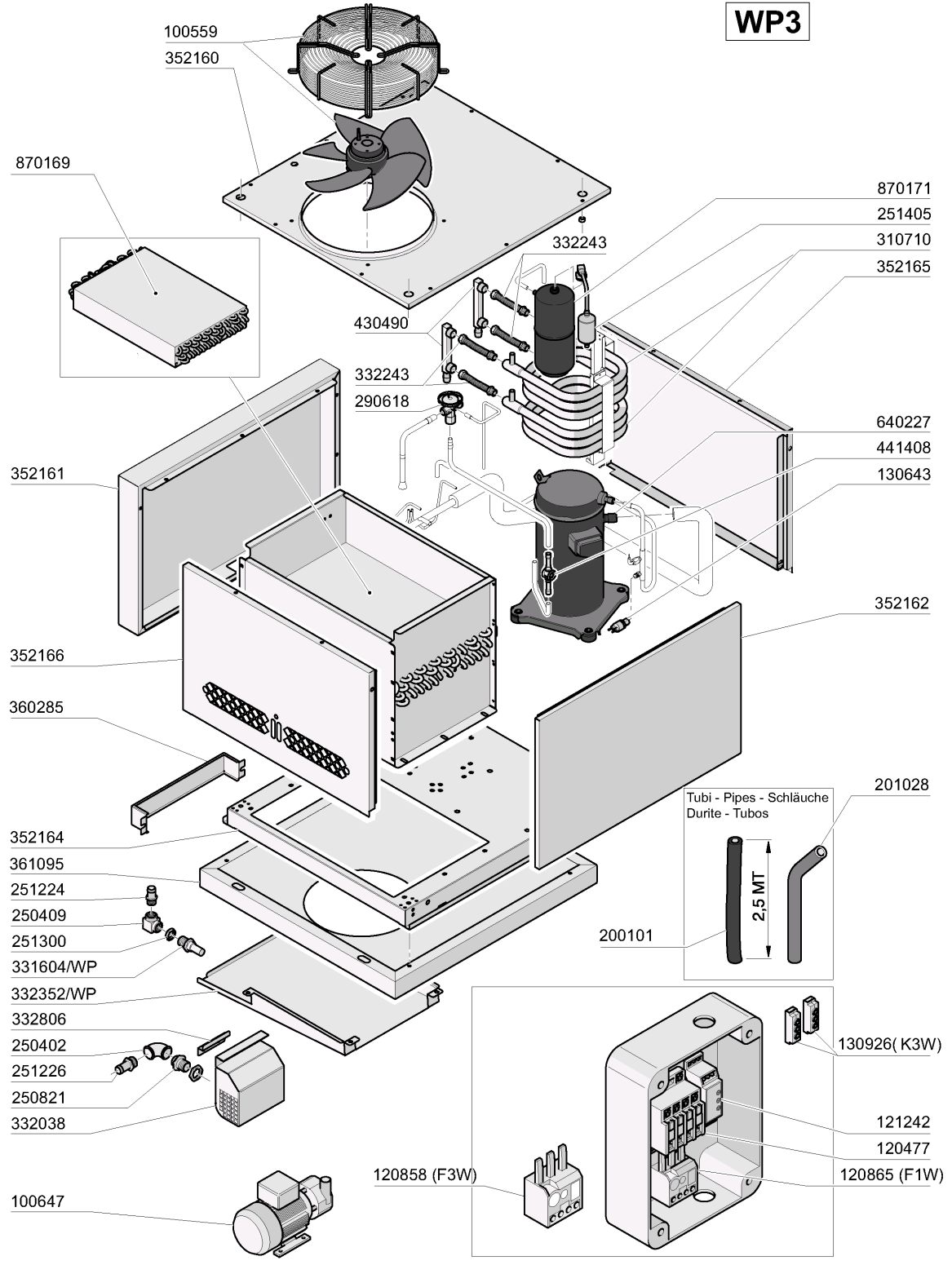

02 - 2010 M. S.

12 - Heat pumps WP3

CODE	DESCRIPTION
100559	FAN WP2-WP3
100647	PUMP HP 0,20 220/240/3 4226
120477	CONTACTOR ABB 9A 220V 50/60HZ
120858	OVERLOAD RELAY ABB 0,4-0,63A
120865	OVERLOAD RELAY ABB 6-8,5A
121242	TIMER LAV1000
130643	HIGH PRESSURE PRESS.SWITCH WP
130926	CONTACT ABB 1NO
200101	RUBBER TUBE 25X35
201028	OUTLET HOSE F. PREWASH 400MM A
250402	INOX ELL FF 3/4"
250409	INOX ELL FF 1/2"
250821	NIPPLES FOR STEAM COIL
251224	NIPPLE 1/2" WP
251226	NIPPLE 3/4" WP
251300	S/S LOCK NUT 1/2" AC-ACR
251405	FILTER WP4
290618	TERMOSTATIC VALVE WP2-WP3
310710	GAS/WATER CONDENSER WP3
331604/WP	TUBO PER RICIR. ACQUA GE WP2/3
332038	FILTER FOR PUMP
332243	HOSE 1/2-3/4"-130X220-
332352/WP	PARASPRUZZI VAP."GE" WP2-WP3
332806	BRACKET WITHOUT ASP.FILTER WP
352160	COVER WP2-WP3
352161	BACK COVER WP2-WP3
352162	FRONT COVER WP2-WP3
352164	BASEMENT WP2-WP3
352165	RIGHT SIDE PANEL WP2-WP3
352166	LEFT SIDE PANEL WP2-WP3
360285	BACK COVER WP2/3
361095	SUPPORT
430490	COLUMN WP
441408	INDICATORE DI FLUSSO (WP)
640227	RICEVITORE LIQUIDO (WP2-WP3)
870169	EVAPORATORE (WP2-WP3)
870171	COMPRESSORE POMPA WP3